



# Instrument Handbook

Optimus+ Sound Level Meters



## About this manual

The instructions in this user manual refer to the operation of Cirrus Research plc Optimus sound level meters with version 5.0 or higher of the firmware.

The instruments described in this manual are the Optimus Yellow (CR:150 series), Optimus Red (CR:160 series), Optimus Green (CR:170 series) and Optimus Purple (CR:190 series).

Some functions described in this manual are only available on Red or Green versions of the Optimus sound level meter. Where functions are applicable to only some instruments in the range, this will be clearly indicated in the text.

This manual describes the recommended usage of the Optimus. Any warnings will be indicated by the following symbol:



The additional information required for testing in accordance with IEC 61672 is provided as a supplementary document, Optimus Sound Level Meters Technical Data Part B, which is available for download at:

[www.cirrusresearch.co.uk/library/user-manuals/](http://www.cirrusresearch.co.uk/library/user-manuals/)

It is not possible to change the way that the instrument measures through the software or firmware. Any legal metrology aspects of the instrument cannot be affected by any changes made in the instrument.

The Common Specifications section on page 35 defines which standards relate to the different functions available in the instruments. Additional approvals and certifications may apply to the instruments and these will be listed in the Appendices.

More detailed explanations of the audio recording templates, tonal noise detection and the repeat measurement timers are available to download from the Cirrus website at [www.cirrusresearch.co.uk/library/user-manuals/](http://www.cirrusresearch.co.uk/library/user-manuals/)

---

## Copyright

Copyright © Cirrus Research plc 2010-2023

All rights reserved.

You may re-use this document/publication (not including the Cirrus Research plc logo and other product logos) free of charge in any format for research, private study or internal circulation within an organisation. You must re-use it accurately and not use it in a misleading context.

You must not modify text, images or illustrations in any way. The material must be acknowledged as Cirrus Research plc copyright and you must give the title of the source document/publication.

Where any third-party copyright material is identified you will need to obtain permission from the copyright holders concerned.

### Trademarks

Cirrus Research plc, the Cirrus Research plc Logo, doseBadge, DOSEBADGE, Optimus, the NoiseTools Logo and the Noise-Hub Logo are either registered trademarks or trademarks of Cirrus Research plc in the United Kingdom and/or other countries. Microsoft and Windows are registered trademarks of Microsoft, Inc. All other trademarks acknowledged.

### Updates

In the interests of continuous product improvement, Cirrus Research plc reserves the right to make changes to product specifications without notice.

To understand the latest updates that have been implemented into this product and to download the most current version of this user manual, visit our website at [www.cirrusresearch.co.uk](http://www.cirrusresearch.co.uk)

Revision 6 | April 2023

## Contents

<b>1. Introduction</b>	<b>5</b>
<b>2. First use</b>	<b>7</b>
2.1 Inserting the batteries	8
2.2 Setting the clock	8
2.3 Calibration	9
<b>3. Making a measurement</b>	<b>11</b>
<b>4. Operations in more detail</b>	<b>12</b>
4.1 NoiseTools	12
4.2 Keypad and controls	12
4.3 Connectors	13
4.4 Screen saver	14
4.5 Display	15
4.6 Audio recording	17
4.7 Timers	18
4.8 Back erase/pause	18
4.9 Memory	19
4.10 Restore factory settings	19
4.11 Windshield	19
4.12 Bluetooth	20
4.13 GPS	20
<b>5 Getting to know your instrument - features &amp; capabilities</b>	<b>27</b>
5.1 Views	27
5.2 High-level noise measurement	30
<b>6 Menus</b>	<b>31</b>
<b>7 Additional information</b>	<b>34</b>
<b>8 Appendices</b>	<b>35</b>
8.1 IEC 61672 test data	35
8.2 Common specifications	35
8.3 Views	38
8.4 Stored measurements	41
8.5 Electrical outputs	44
<b>9 Acoustic calibrator information</b>	<b>46</b>
9.1 Setting up the calibrator	46
9.2 Calibrating a sound level meter	46
9.3 Changing the battery	47
9.4 Specifications	48
9.5 Technical information	48
<b>10 Declaration of Conformity</b>	<b>50</b>
<b>11 Product guarantee and extended warranty</b>	<b>51</b>

---

## 1. Introduction

Welcome to your Optimus sound level meter. This next-generation instrument from Cirrus Research plc is powerful yet simple to use and is capable of a wide range of noise measurement functions.





## 2. First use

Your sound level meter has been shipped in reusable packaging that should be retained for safe shipment when returning the instrument for calibration or servicing.

All Optimus sound level meters come with the following standard accessories:

- MV:200 microphone preamplifier
- Microphone capsule (attached to the preamplifier)
- Wrist strap
- 4 x AA batteries
- User manual
- Windshield

You may have other accessories, depending on your package.



When connecting the preamplifier, please take great care to only turn the locking ring at the base.

Twisting the preamplifier body is likely to cause serious damage. The microphone capsule is also delicate, and care needs to be taken when handling it.

Damage caused by misuse is not covered by the warranty for the instrument.





## 2.1 Inserting the batteries

Your sound level meter is powered by 4 x AA alkaline batteries (also called MN1500 or LR6). We recommend that you use alkaline batteries to give the best performance.

Remove the battery cover by loosening the captive locking screw (as shown in the diagram below).



Please look carefully at the diagram inside the battery compartment that shows the correct polarity. After inserting the batteries in the correct orientation, replace the cover and tighten the locking screw.

The instrument is switched on by pressing and releasing the on/off button on the left-hand side of the case. After the bootup screen has been displayed, your sound level meter will show the last view you used.

## 2.2 Setting the clock

Your instrument stores the date and time with all measurements to help when analysing results and ensuring the accuracy of the data. It is important to check that the instrument's clock is correctly set before starting a measurement session. It is visible on the top-right corner of the screen.

To set the clock, press the 'menu' button after the instrument has been turned on. Select the 'Set Clock' menu and follow the instructions on-screen.

Please note that the clock might need to be set again if the instrument is stored without batteries for a prolonged period.

---

## 2.3 Calibration

All noise measuring instruments should be calibrated before each use because the microphone is susceptible to minor damage, even from small knocks.

The calibration process applies corrections (if needed) to your instrument's readings, to ensure that your measurements are as accurate as possible.

Calibration should also be carried out at the end of a measurement session to make sure that nothing has happened to the instrument during the session.

To calibrate your sound level meter, carefully push the microphone into the cavity at the end of the calibrator. Ensure the microphone is fully inserted into the cavity and is past the 'O' ring seals.

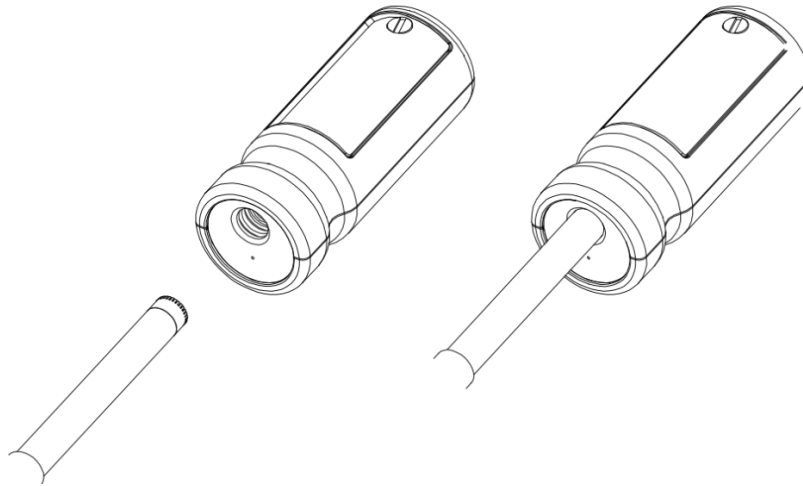

Ensure that the small bleed hole next to the microphone cavity on the calibrator is not blocked, as this could cause damage to the microphone.



Take care not to use a twisting motion when pushing the microphone into the calibrator, as this is likely to cause damage to the preamplifier.

Press the 'on' button on the end of the calibrator. Press the calibrate button on your sound level meter.

The instrument will measure the sound level from the acoustic calibrator to determine if it is within the required tolerance and levels. The calibration level must be stable to within  $\pm 0.075$  dB for 5 consecutive seconds, for calibration to be successful.

When calibration is complete, your instrument will display the level along with the correction or adjustment made.

Your sound level meter is pre-set with the correction values needed for Cirrus Research microphone capsules, so no manual adjustment is required. The calibration level you should expect is 93.7 dB.

Refer to page 46 for detailed operating information for the CR:517, CR:514 and CR:515 acoustic calibrators.

---

### 3. Making a measurement

Press the 'start' key to begin recording (on data logging instruments with the VoiceTag function switched on, the VoiceTag screen will show – press 'skip' to move on without recording a note).

Your sound level meter is now measuring and recording noise data for all available functions, regardless of your selected view, and the red animated running icon will show in the top left of the information bar.

The measurement can be paused by pressing the 'pause/stop' soft key.

Press once to pause/back-erase and twice to stop, or alternatively press and hold for three seconds to stop.

The pause/back-erase function is only available if this has been enabled in the instrument menu (more information on page 18).

To stop the measurement, press the 'stop' key. The instrument will change from measurement to review mode, and your data is stored and ready to review and download. For instruments without data logging, only the last recorded measurement is available for review.

## 4. Operations in more detail



Please note: from this chapter on, the manual describes capabilities which are available on different models within the Optimus range. This includes the CR:15XX, CR:16XX and CR:17XX instruments.

If you are unsure which capabilities your instrument has, you can check by looking at the general view/page 5 (and 6 on some models).

### 4.1 NoiseTools

All Optimus sound level meters can be used with the licence-free NoiseTools software, which can be used to configure the instrument (some options are only configurable within NoiseTools and not on the instrument – it will be made clear in the text where this is the case).

NoiseTools is also a powerful platform for storing, analysing and organising your data, and can produce reports for publication. VoiceTag notes and audio recordings can only be played back through NoiseTools.

### 4.2 Keypad and controls

Your sound level meter is controlled via the four arrow keys (up, down, left and right), centre select key and three soft keys. The soft keys change their function depending on the mode that the instrument is in. The soft key function is shown above the button on the display.

The left and right keys move between the views and the up and down keys move between the pages of each view.

The function of the centre button varies depending on the screen being viewed, and duplicates one of the soft keys. Its function includes 'menu', 'select', 'OK' and 'exit review' of measurements.

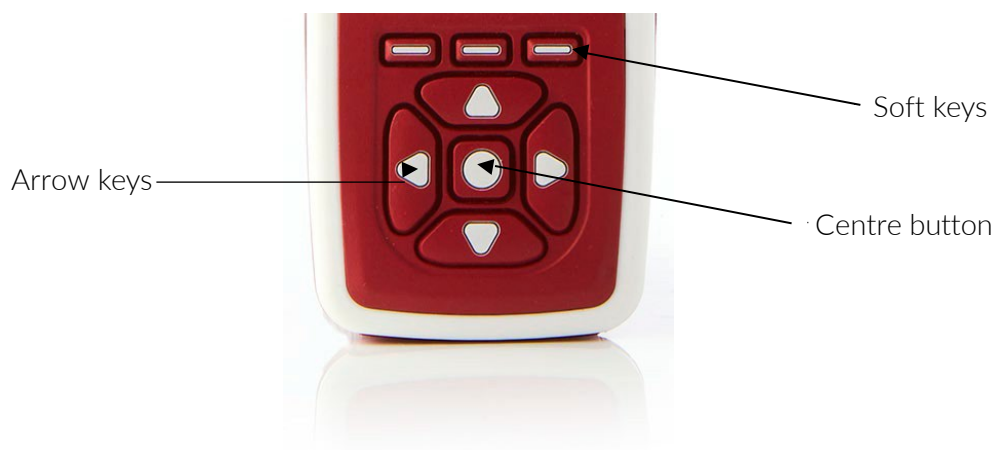

The ambient light sensor on the front of the instrument will illuminate the keypad and adjust the brightness of the display automatically when the light level falls.

If the pause function has been activated (described on page 18), the right soft key switches between pause and stop. Press once to pause/back-erase the measurement, and twice to stop the measurement. Alternatively, press and hold the button for three seconds to stop the measurement.

### 4.3 Connectors

The connectors used by your sound level meter to communicate with a PC and NoiseTools are at the bottom of the instrument under a protective cover.



Your sound level meter can be powered via the multi-pin connector on the bottom of the instrument. Power can be connected using a ZL:171 Optimus power input cable (2.1 mm power jack, 2 m) or via a ZL:176 Optimus 12 V battery pack cable.

The instrument can also be powered from an external source, such as a USB connection to a PC or via a USB power supply.

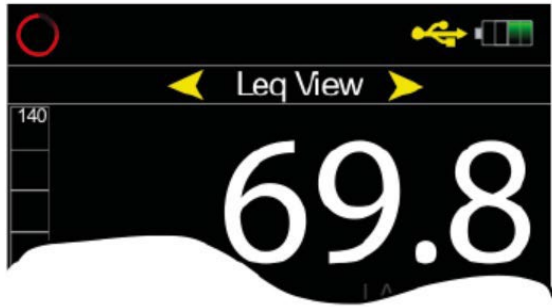

External power via USB

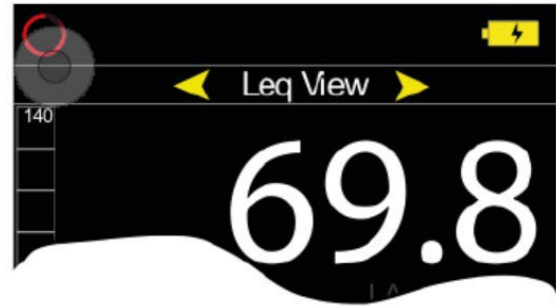

External power via multi-pin connector

An AC output is available on the instrument via the 3.5 mm jack socket. The output is unweighted, and the output level can be adjusted using the options in the AC-out menu.

This output can be used with external instrumentation. See page 44 for details of the electrical outputs.

#### 4.4 Screen saver

If no keys are pressed for six minutes the display will dim to preserve battery and screen life and reduce power consumption. After 30 minutes with no key presses, the display will switch off completely and the keypad will flash every two seconds to show that the instrument is still powered. The screen dim and screen saver functions will operate during measurements as well as when the instrument is not measuring. Press any key to turn the display back on.

The time intervals for the screen dim and screen saver are configurable in NoiseTools.

## 4.5 Display

The instrument uses a high-resolution colour screen to show a clear and easy-to-read display of all the information you need.

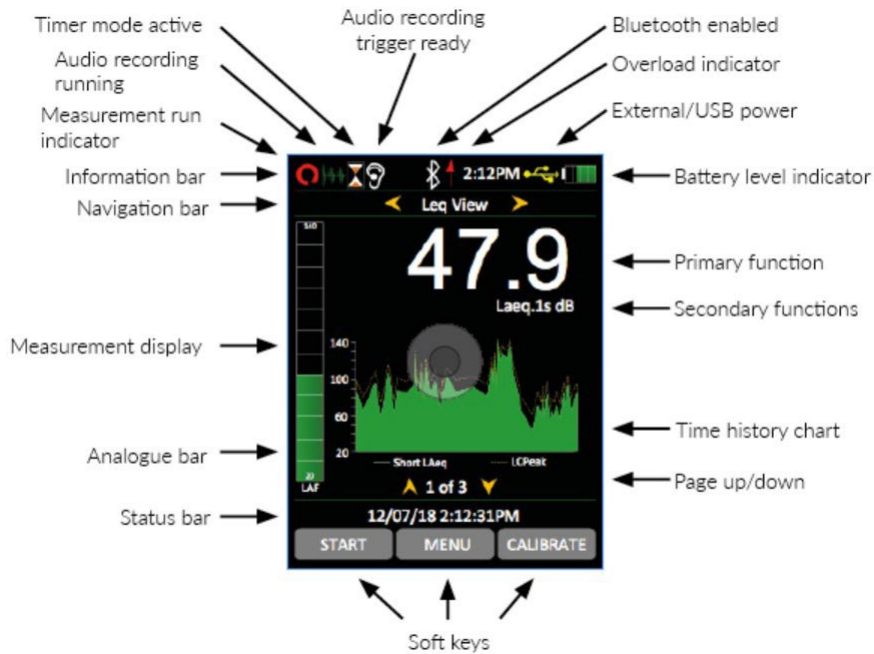

### 4.5.1 Information bar

The information bar shows icons when functions are active. Examples of the icons are shown in the diagram above.

### 4.5.2 Navigation bar

The navigation bar shows which view or menu you are looking at.

### 4.5.3 Measurement display

In addition to primary and secondary functions, the display features an analogue bar on the left of the screen, which shows real time A-weighted sound level.

At the bottom of the screen is the page information for your view, i.e. 1 of 3.



#### 4.5.4 Status bar

When the instrument is not measuring, the status bar shows the date and time. When it is measuring, it shows the elapsed time and in review mode, it shows the measurement number and the total number of measurements stored.

#### 4.5.5 Overload and under-range indication

Overload is indicated by a red arrow (↑) shown in the information bar.

Overload is also indicated by the word 'overload' and under-range is indicated by the word 'under range' (in the chosen language) on the display. On the sound level view and Leq view, the indicators are situated beneath and to the left of the large number.

When a measurement is not in progress, the indicator is shown for at least one second, so that very short transient overload or under-range conditions are visible to the operator.

When a measurement is in progress, the overload indicator stays on until the measurement is stopped or reset.

In some circumstances the overload and under-range indicators will be shown simultaneously. In this case the text will be abbreviated to save space.

Note that if any displayed decibel value on the sound level view or Leq view is below 14.0 dB, the value will be replaced by dashes ('--'). These levels are typically below the noise floor of the microphone capsule and so will only be encountered during electrical testing.

#### 4.5.6 'Bluescreen'

Under rare circumstances when the instrument encounters a condition it cannot recover from, a 'bluescreen' error message will show with an error code. If this should happen to your instrument, please make a note of the code so engineers at Cirrus Research can diagnose your problem accurately. After writing down the code, pressing the right key will clear the screen and the instrument can be used as normal.

#### 4.5.7 Battery indicator

The status of the batteries is shown in the battery level indicator. When the batteries need replacing, the indicator will turn red.

#### 4.5.8 Low battery indication while switching on

If the start-up screen flashes quickly when you press the 'on' button, the batteries have insufficient power to start, and need replacing.

---

## 4.6 Audio recording

Audio recording can be started manually using the audio soft key or automatically using the audio triggers.

This starts the instrument recording raw WAV data at a quality that can be set in the menu (standard, high or studio).

Details of the audio triggers can be found in Technical Note 28 - Audio Recording with the Optimus Green sound level meters. Please refer to the Cirrus Research plc website at [www.cirrusresearch.co.uk/library/optimus](http://www.cirrusresearch.co.uk/library/optimus).

Pressing the audio key again stops the recording. There is no maximum duration of an audio recording set by default, but this can be changed in NoiseTools, and the parameters for the audio triggers can be configured in NoiseTools.

The audio recording includes a 10 second back buffer (on the standard quality setting). When triggering a recording manually, it is very difficult to record the beginning of a sound that catches your attention.

The back buffer will cover the time it takes you to respond and press 'record'. 10 seconds is the default duration, which can be changed in NoiseTools.

The time history display and analogue bar turn **blue** when audio recording is running and revert to **green** when it has stopped.

Starting and stopping audio recordings during a measurement does not affect the noise measurement data being recorded.

Please note, VoiceTags are recorded BEFORE the measurement starts and are for spoken notes only, not for analysis of recorded sounds.

## 4.7 Timers

The single and repeat timers allow you to make precisely timed measurements over pre-set or custom defined durations, which are set on the instrument using the storage options menu (see next chapter).

The repeat timer allows measurements to be stopped and started automatically over a long period of time. The instrument can still be stopped and started manually when the repeat timer is active.

The repeat timer is synchronised to the real-time clock, so if you choose a 30-minute duration, the measurement will begin on the hour and at 30 minutes past. When the measurement ends, a new one will begin and last for the next 30-minute interval.

If the instrument is paused when an automatic timer begins, the new timed measurement will also be paused.

The single timer allows measurements to automatically stop after a pre-defined period. If you set the single timer duration to 15 minutes and enable the single timer option, then all measurements will automatically stop after 15 minutes.

*(Firmware version 2.8 and above)* The single timer can also be set using the NoiseTools software to halt when the measurement is paused. This allows a measurement to have an exact 'non-paused' duration. For example, if you set the single timer to two minutes and pause the measurement for 30 seconds, the measurement will automatically stop after two minutes and 30 seconds instead of after two minutes.

## 4.8 Back erase/pause

### 4.8.1 Pause

Your sound level meter provides pause and back-erase functions, which can be used during a measurement.

When the pause function is enabled in the menu, the 'stop' button is replaced by the 'pause/stop' button. This also enables the back-erase function, the duration of which can be set in the menu.

Please note that the measurement will automatically resume after five minutes in pause mode.

### 4.8.2 Back-erase

The back-erase function allows a section of the measurement to be removed from the data used, to calculate the overall values.

---

An example of this would be if, during the measurement of cars on a road, a large truck passed by the measurement location. If the intention was only to measure cars, the truck can be excluded from the overall measurement data by pressing the 'pause' button and then using back erase to remove a pre-set section of noise.

The time that the 'pause' button was pressed, along with the back-erase duration, will be excluded from the calculation of the overall noise values such as the Leq, Lmin, Lmax, LPeak, and the 1:1 and 1:3 octave band overall values.

The duration of the back erase can be set to between one and 30 seconds using the menu and can also be configured in the NoiseTools software. If the pause function is disabled, the back-erase function is also disabled.

## 4.9 Memory

The instrument has 4GB of memory as standard. This is partitioned into two sections, one to record time history and one for audio (VoiceTags and audio recordings). The space allocated to each can be configured in NoiseTools.

The free space in the memory is shown in the general view as days or hours available for both time history and audio. When either partition is full, the instrument will overwrite the oldest data in that partition.

To clear the memory and permanently delete all stored data, choose the 'clear memory' menu page and follow the instructions on-screen. Before permanently erasing the data, you will be asked to press 'OK' to confirm.

## 4.10 Restore factory settings

This is in the 'Advanced Options' menu and restores the instrument to the default options for all user-definable settings in the menus, and clears the calibration offset. For settings such as 'language' where there is no default, the instrument will return to the option it was shipped with.

Follow the on-screen instructions, and press 'OK' to confirm. This does not delete any stored measurements.

## 4.11 Windshield

The instrument can be used with a UA:237 90mm foam windshield, which will reduce the noise levels generated by air turbulence over the microphone capsule. It can also help protect the microphone capsule from dust and fluids, which can affect the performance of the instrument.

## 4.12 Bluetooth

The instrument can be connected to a Bluetooth low-energy mobile device to allow control, live view and overall measurement download. To connect to a device, download the dBActive application from your smartphone's app store. On the instrument, go to the 'Advanced Options' menu and select the 'Bluetooth' page. Enable Bluetooth.

The connection between the mobile device and the instrument requires pairing; this prevents any unauthorised connections being made.

Run the app on the mobile device and scan for any devices. Select the instrument you wish to connect to. A pair request will be asked for; the pair key is displayed on the Bluetooth page of the instrument. Enter this into the mobile device.

The Bluetooth symbol in the information bar turns green when connected.

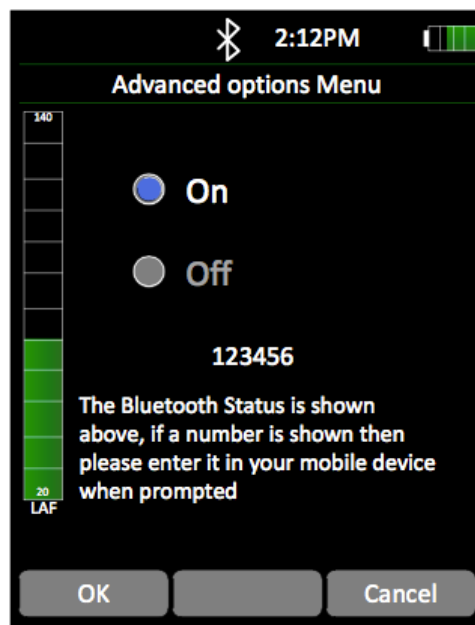

Please note: Bluetooth on the instrument is connected to Port 2, meaning that it cannot be enabled at the same time as the GPS function.

## 4.13 GPS

Specific variants of the Optimus sound level meter come equipped with GPS functionality.

### 4.13.1 Fitting the GPS Module

Remove the protective cover from the base of your instrument.



Remove the plastic cover from the back of your instrument.



Fully insert the GPS Module into the base of your instrument. Fit the wrist strap as required.



The GPS Module is now ready to be configured using NoiseTools. Fit the the protective cover to the GPS Module.



#### 4.13.2 Configuring the GPS Module

This section details how to configure your instrument to work with the GPS Module. For the GPS Module to operate correctly, your instrument must have firmware version 5.5.3015 or later installed. Please consult page 2 of the General View on your instrument to check the firmware version installed. Please contact Technical Support for help with firmware upgrades.

You will also need the latest version of NoiseTools installed on your PC/laptop. Please visit the Cirrus Research website to download the most up-to-date software.

If you have purchased the Optimus GPS as a complete unit, your instrument has been supplied preconfigured, so you can skip ahead to the next section.

Open NoiseTools and connect the USB cable between the instrument and your PC.



Click 'Configure' on the 'Instrument' panel.

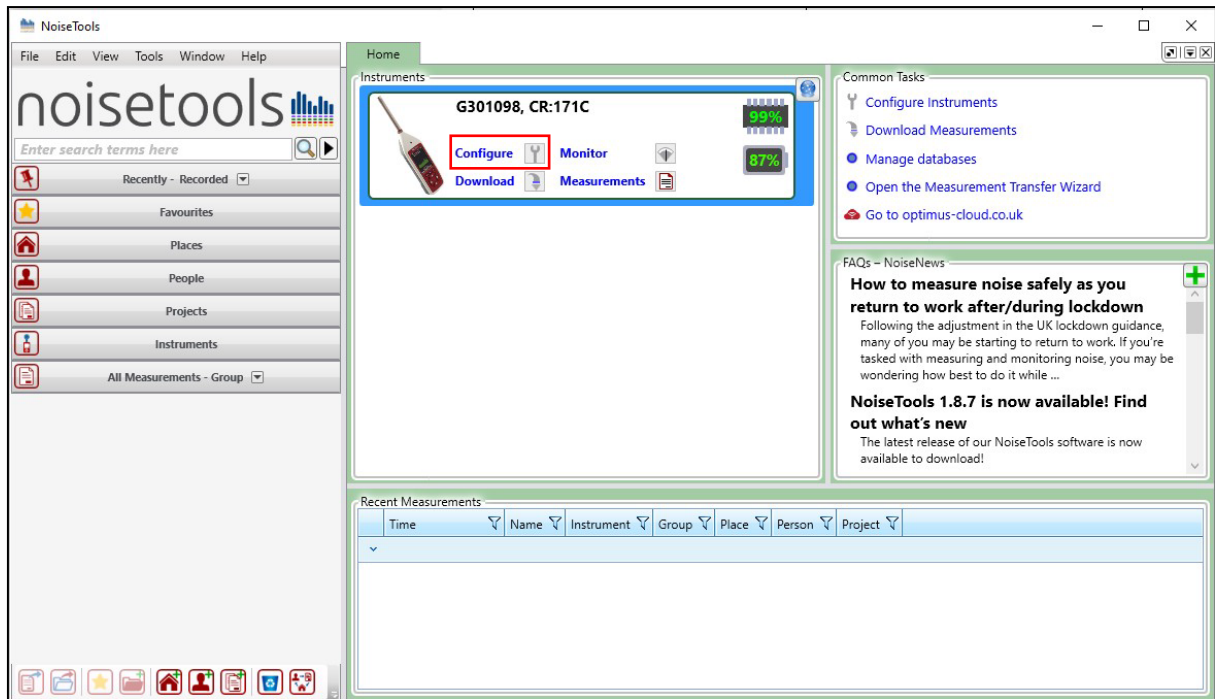

Click the 'Advanced' tab. Change the Port B Serial Port Mode to 'GPS (Module)'.

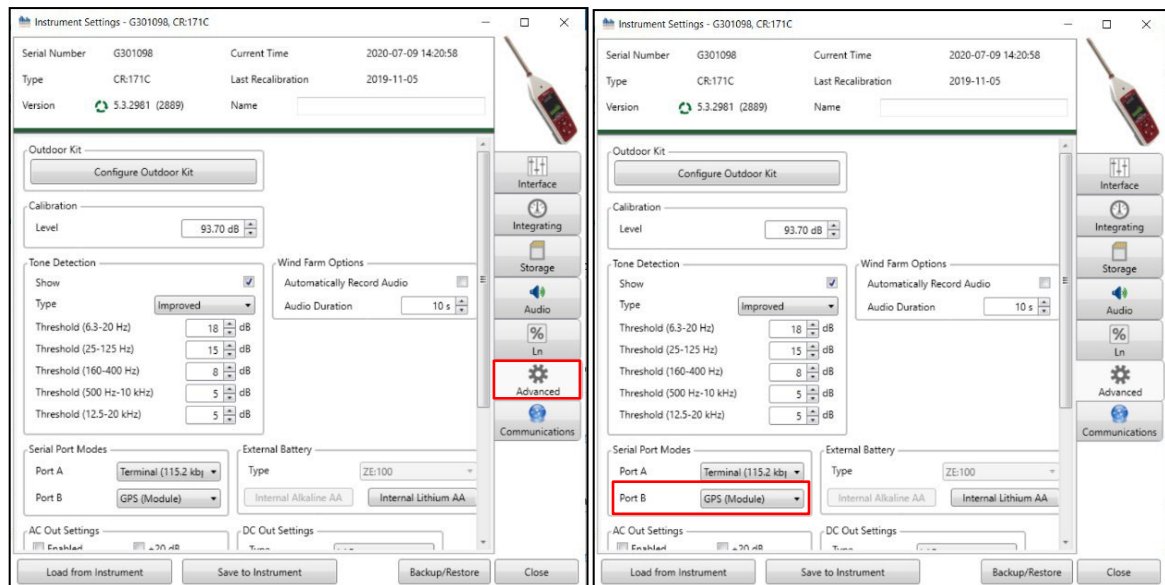

#### 4.13.3 GPS AssistNow Data

NoiseTools automatically downloads GPS AssistNow data to instruments configured to use the GPS Module. This is used to reduce the time to first fix (TTFF).

Typically, the use of GPS AssistNow will reduce TTFF from up to five minutes, to under 60 seconds.



It is highly recommended that before each daily use of the Optimus GPS Module, the instrument is connected to NoiseTools to download the latest GPS Assist Now data, which will complete automatically. Please ensure that the GPS Module is connected to your instrument before turning it on.

#### 4.13.4 GPS Data in NoiseTools

Open a measurement and click 'View Map'.

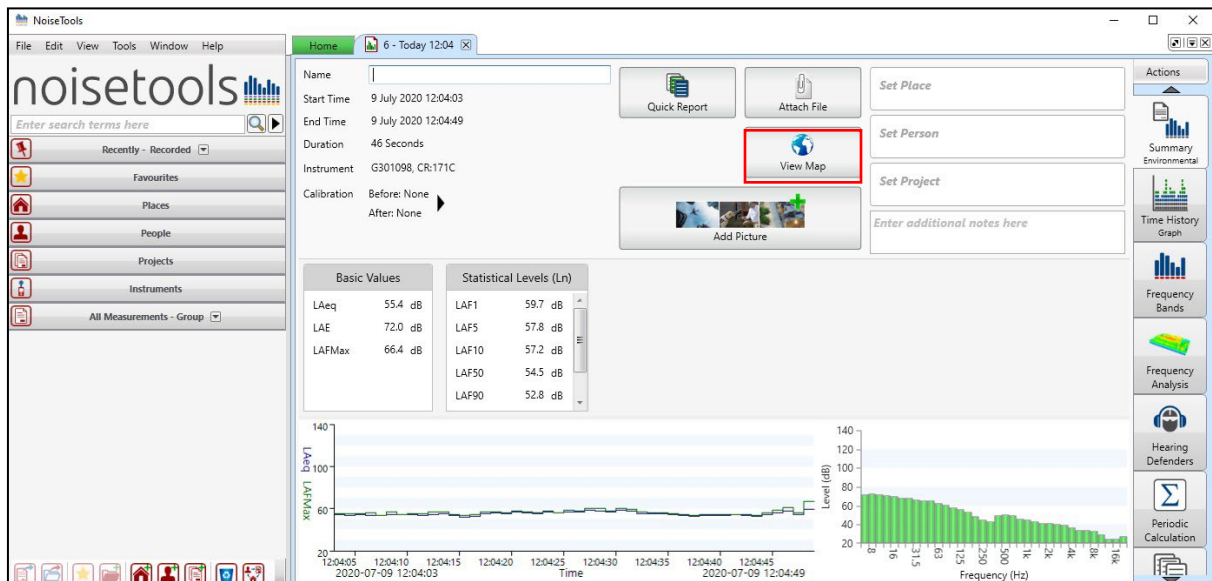

A pin identifies the measurement location.

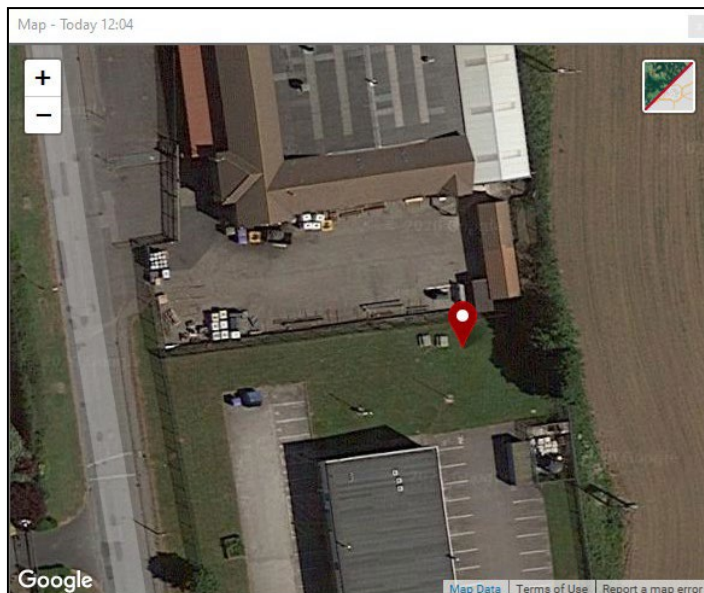

View coordinate data by clicking the 'Detail' tab.

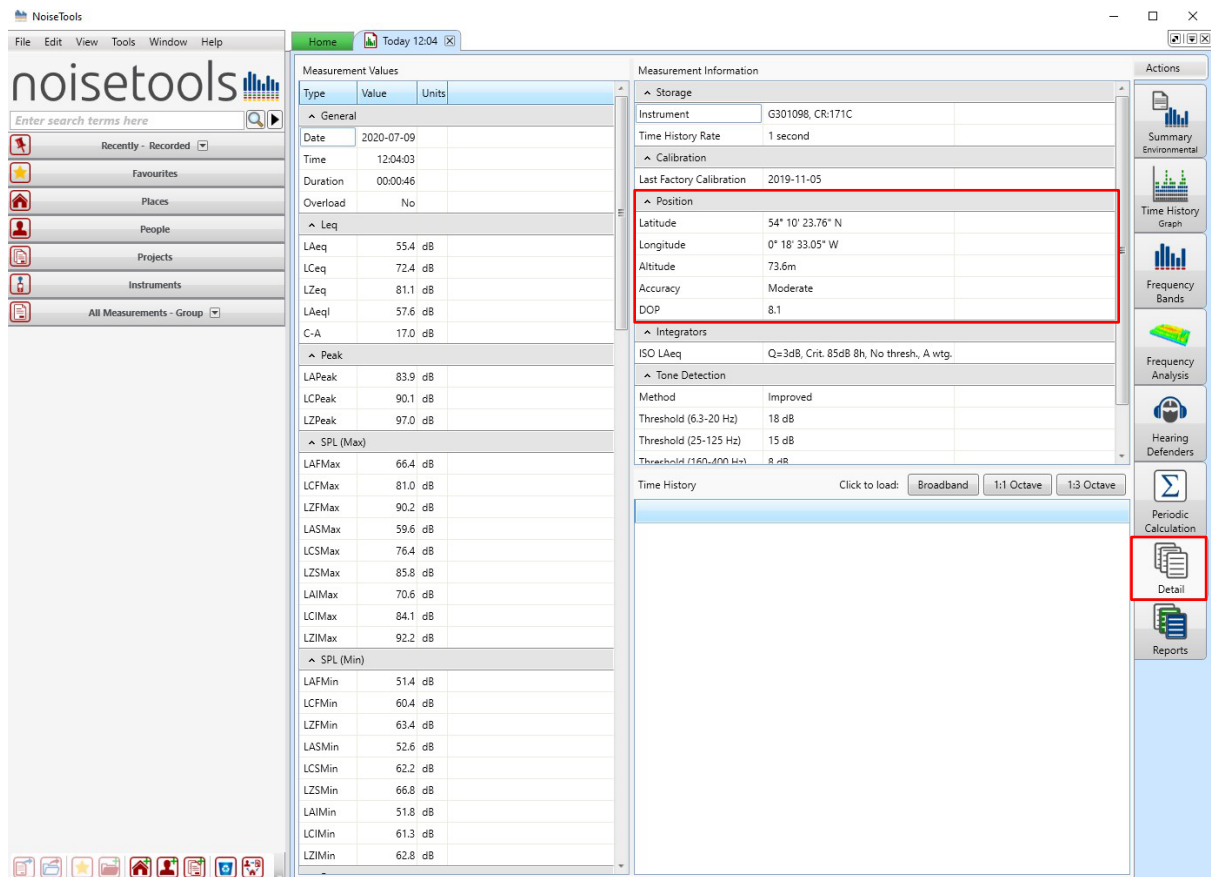

Coordinate and map data will also be visible within NoiseTools reports.

#### 4.13.5 GPS Data on Your Instrument

Navigate to the General View screen and scroll down to page 3.

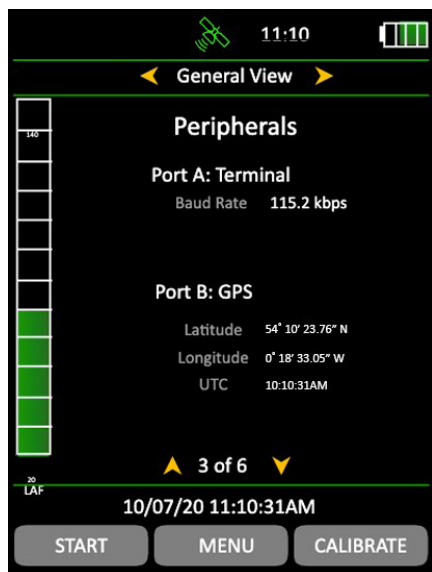

When the GPS Module is attached, a grey satellite icon will be displayed at the top of the instrument's screen.

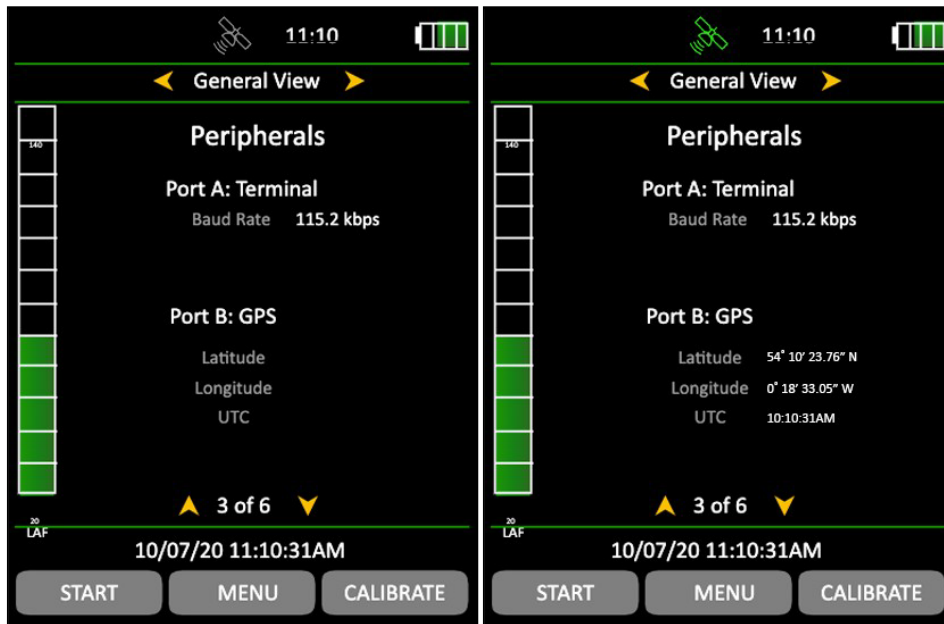

When a GPS signal is acquired, the satellite icon will change to green and coordinate data will be displayed.

Please note: GPS and Bluetooth functionality cannot operate concurrently. GPS functionality is disabled when Bluetooth is enabled and is re-enabled on deactivation of Bluetooth.

## 5 Getting to know your instrument - features & capabilities

Optimus sound level meters are designed around a modular structure that allows an instrument to be upgraded and updated with new capabilities (functions), protecting your investment for the future.

To check which capabilities your instrument has, go to the general view/page 5 (6 on some models). This will list all the available capabilities on your device.

Some options cannot be changed while the instrument is measuring, and a message will appear on the screen warning you that the options 'cannot be changed while measuring'. Some menu choices are disabled while measuring and will appear grey on the screen.

### 5.1 Views

The views are accessed by pressing the left and right control keys. The views are available when the instrument is measuring, not measuring or in review mode, but the pages available in each mode will differ.

#### *Not measuring*

When not measuring, the information shown is live, instantaneous values.

#### *Measuring*

When measuring, these live values are still shown, but you are also shown cumulative overall values for the current measurement period.

#### *Review mode*

In review mode, the values shown are the overall cumulative values for the measurement.

#### 5.1.1 General view

This shows the status of the instrument with the calibration data, the capabilities that are fitted, the firmware version, the serial numbers of the sound level meter, microphone and preamplifier, along with details of the standards that it meets.

#### 5.1.2 Sound level view

This view shows the sound pressure level or SPL, with the maximum and minimum sound level (Lmax and Lmin) with a choice of A, C or Z frequency weightings.

### 5.1.3 Leq view

Shows you the Leq, Peak, LAE (SEL) and C-A values with a choice of A, C or Z frequency weightings.

The C-A data can be used with the HML method for selecting hearing protection.

If the time weighting is set to impulse, the C-A function is replaced by LAeq,I (also known as LAIeq).

When the instrument is set to the German language, an additional 'Taktmaximal' page is also available.

### 5.1.4 1:1 octave band view

This view shows the noise levels divided into octave frequency bands. This can be used to aid in the selection of hearing protection and for noise control applications.

Some models also have the capability to show NR and NC curves and resultant values.

### 5.1.5 1:3 octave band view

This view shows the noise levels divided into 1:3 octave (called 'third-octave') frequency bands. This view can be used for environmental noise measurements and for noise control applications.

The 1:3 octave band view also provides Leq,LF (20 - 200 Hz) and LAeq,LF (20 - 200 Hz).

### 5.1.6 Tone detection

This is a capability displayed within the 1:3 octave view on some instruments.

Instruments with tone detection use either the ISO 1996-2:2007 simplified method or an improved method developed by Cirrus Research, which is based on the ISO standard, extended to include tones between bands, tones in outer bands and Z-weightings. The ISO method only applies to overall data when measuring or reviewing, whereas the Cirrus improved method also applies to instantaneous live values.

When a tone is detected, the band is highlighted in blue on both the graphical and numerical pages.

The tone detection method can be set to either the Cirrus improved method (default setting) or the ISO 1996 method in NoiseTools.

---

For more information, please see Technical Note 32 – Tonal noise detection with Optimus sound level meters, available for download from the Cirrus Research website at [www.cirrusresearch.co.uk/library/optimus/](http://www.cirrusresearch.co.uk/library/optimus/).

#### 5.1.7 Ln view

The Ln view shows the statistical Ln values calculated during the measurement. The first seven Ln values are set by default to commonly used values, and 8-14 are definable in NoiseTools.

Some Optimus models have a second set which are also 1-7 default, 8-14 user definable.

The source data type for the second Ln set is also configurable in NoiseTools

#### 5.1.8 Dose view

The dose view gives you a number of different functions depending upon the configuration of the quick settings.

For the UK option, this view gives you Leq, LEP,d, % dose and estimated dose along with the projected exposure calculator.

For the EU option, this view gives you Leq, LEX,8, % dose and estimated dose along with the projected exposure calculator.

For all other options the Lavg, TWA, % dose and estimated % dose for two integrators, in addition to ISO (EU), will be shown according to the setting you have chosen.

Two custom integrators can also be used, configured in NoiseTools. When chosen, they will be shown in addition to ISO (EU).

#### 5.1.9 Moving average view

The moving average view is available on the CR:19xBE instruments only.

The moving average view shows a 15 minute and 60 minute moving average LAeq along with LASMax and L95 values.

The moving average LAeq values are highlighted in colours under certain conditions (see pages 39 for more details).

#### 5.1.10 Environmental view

The environmental view provides quick access to a set of parameters that are commonly used for environmental noise measurements.

---

The displayed values will differ depending upon the language selection chosen for the instrument.

#### 5.1.11 Vehicle noise view

The vehicle noise view and optional wired remote is designed to meet the requirements of ISO 5130-2019 & §29 StVZO for the measurement of sound pressure level emitted by stationary road vehicles.

Each time the remote button is pressed an LAFMax value is taken, and the last three measurements are averaged and displayed.

Please note that the instrument should be configured to display Fast time weighting.

## 5.2 High-level noise measurement

The Optimus sound level meters can be used to measure high noise levels (up to 170 dB) with the use of the optional MV:200EH high level noise measurement option.

This consists of a microphone capsule, attenuator, and preamplifier, supplied as a complete unit. Switch off the instrument before fitting the MV:200EH.

Once the unit is fitted, calibrate the sound level meter as standard. The instrument will detect the MV:200EH and adjust the measurement span to 50-170 dB.

If the standard microphone and preamplifier are replaced, re-calibrate the instrument to return the measurement span to the standard 20-140 dB range.

## 5.3 Measurement ID

In measurement review mode, page 2 of General Review displays the unique measurement ID. This is generated from the processor UID and a unique instrument measurement number, thereby creating a unique measurement ID, which cannot be duplicated.

---

## 6 Menus

In the following menus, different options can be chosen on the instrument. To activate a function, press the 'mark' soft key to put a tick in the square box.

You can now use the up and down soft arrow keys to select your setting and use the 'OK' soft key to confirm it. In the menu pages, the status bar will display information about your current settings and the option you have chosen.

The following chapter shows the navigation between the menus and pages, and the options available. For more detailed information, please see the appendices.

### 6.1.1 Main menu

- Restart
- Review stored data
- Clear memory
- Advanced options
- View options
- Storage options
- Quick settings
- Set clock

### 6.1.2 Restart

Pressing 'restart' at any time during a measurement resets the elapsed time to zero and deletes the data for that measurement only.

### 6.1.3 Review stored data

The left and right keys navigate between the different views (see previous chapter for details), and the up and down keys navigate between the pages of each view. The status bar will tell you which measurement you are looking at out of the total (for example measurement 4 of 9).

### 6.1.4 Clear memory

Permanently deletes all stored measurements.

### 6.1.5 Advanced options

*Bluetooth*

On/off

Pairing key and pairing status

---



*Restore factory settings*

Restores the instrument back to its original factory setup.

*AC out*

On/off

+20 dB Gain

High levels (70-140 dB) or low levels (20-90 dB)

*Audio quality*

Standard quality (16-bit, 16 kHz)

High quality (24-bit, 48 kHz)

Studio quality (32-bit, 96 kHz)

*Audio triggers*

On/off

Default (75 dB LAeq, no minimum time) – user adjustable on the instrument

Select any user-programmed triggering templates

*Pause*

On/off

Back erase duration (0-30 seconds)

Note: After 5 minutes in the pause state, the instrument will restart.

*Auto audio*

On/off

Set duration for length of audio to be recorded at the start of a measurement (10 to 120 seconds)

### 6.1.6 View options

*Set level colours (analogue bar)*

Defaults: 80 dB = Yellow, 85 dB = Red

User selectable

*Time weighting*

Fast, Slow, Impulse

*Adjust screen brightness*

Fixed, Auto (default)

*Set date/time formats*

dd/mm/yy, mm/dd/yy, dd.mm.yy, dd-mm-yy, yy-mm-dd

hh:mm:ss, hh:mm:ss AM/PM

---

### *Language*

English, Français, Deutsch, Español, Italiano

Please note: when changing language, the instrument must be restarted for the change to take effect.

### 6.1.7 Storage options

#### *Time history rate*

2s, 1s (default), ½s (500 ms), ¼s (250 ms), 1/8s (125 ms), 1/10s (100ms), 1/16s (62.5ms), 1/100s (10ms)

Selected rate applies to all measurements including octaves.

#### *VoiceTag*

On/off

#### *Single timer*

On/off

1 min, 2 min, 5 min, 15 min, 30 min, 1 h, custom (default 10 min)

#### *Repeat timer*

On/off

1 min, 2 min, 5 min, 15 min, 30 min, 1 h, custom (default 10 min)

Day/evening/night

### 6.1.8 Quick settings

UK

EU

OSHA HC and PEL

OSHA HC and ACGIH

MSHA HC and EC

Custom

### 6.1.9 Set clock

Follow the instructions on the screen to set the date and time using the format set in View Options/Set Date and Time Format above.

## 7 Additional information

Additional information on the following topics can be downloaded from the Cirrus Research website. Please visit [www.cirrusresearch.co.uk/library/optimus/](http://www.cirrusresearch.co.uk/library/optimus/) for the latest versions of these documents.

Technical Note 28 - Recording audio with the Optimus Green (CR:170) sound level meters

Technical Note 29 - Timer mode options

Technical Note 30 - Project exposure calculation

Technical Note 31 - NR & NC curves

Technical Note 65 - What is AuditStore and How Does it Work?

Other documents may also be available for the Optimus sound level meters. Please visit the Cirrus Research website for the latest information.

---

## 8 Appendices

### 8.1 IEC 61672 test data

Technical data for IEC 61672 testing is contained in the Part B document, which can be downloaded from the Cirrus Research plc website.

This chapter of the manual contains the overall specifications for the Optimus Yellow (CR:150), Optimus Red (CR:160), Optimus Green (CR:170) and Optimus Purple (CR:190) sound level meters.

### 8.2 Common specifications

Applicable standards	
IEC 61672-1:2013 Class 1 or Class 2 Group X	CR:151 & CR:152 All versions CR:161 & CR:162 All versions CR:171 & CR:172 All versions CR:191BE, CR:192BE, CR:193BE & CR:194BE
IEC 60651:2001 Type 1 I or Type 2 I	CR:151 & CR:152 All versions CR:161 & CR:162 All versions CR:171 & CR:172 All versions
IEC 60804:2000 Type 1 or Type 2	CR:161 & CR:162 All versions CR:171 & CR:172 All versions
IEC 61252:1997 personal sound exposure meters	CR:161 & CR:162 All versions CR:171 & CR:172 All versions
ANSI S1.4 -1983 (R2006)	CR:161 & CR:162 All versions CR:171 & CR:172 All versions
ANSI S1.43 - 1997 (R2007)	CR:161 & CR:162 All versions CR:171 & CR:172 All versions
ANSI S1.25:1991	CR:161 & CR:162 All versions CR:171 & CR:172 All versions
IEC 61260:1995* & ANSI S1.11-2004 1:1 octave band filters Class 1 or Class 2	CR:161C & CR:162C CR:161D & CR:162D CR:171A,B,C & CR:172A,B,C CR:193BE & CR:194BE
IEC 61260:1995* & ANSI S1.11-2004 1:3 octave band filters Class 1 or Class 2	CR:171B & CR:172B CR:171C & CR:172C CR:193BE & CR:194BE

\*The Optimus implements base-2 1:1 octaves and 1:3 octaves pers IEC 61260-1:1995. This standard has now been superseded by IEC 61260-1:2014, which specifies-10 filters only.

Specifications	
Microphone	Class 1 instruments: MK:224 or MK:229 pre-polarized free-field 1/2" Condenser Class 2 instruments: MK:216 pre-polarized free-field 1/2" condenser
Microphone preamplifier	MV:200 removable preamplifier for Class 1 & Class 2 instruments
Measurement range	A single measurement range covering 120 dB without any adjustment
Linear operating range	In accordance with IEC 61672: A-weighted: 24 to 139 dB C-weighted: 30 to 139 dB Z-weighted: 45 to 139 dB
Self-generated noise	<19 dB(A) Class 1, <22 dB(A) Class 2
Frequency weightings	RMS: A, C, & Z measured simultaneously Peak: A, C, & Z measured simultaneously
Time weightings	Fast, Slow & Impulse measured simultaneously
Display	High resolution display with ambient light sensor & illuminated keypad
Display of	Measured parameters Recalled measurement parameters (data logging versions) Battery level & external power connection Overload & under-range Time & frequency weighting Elapsed measurement time Instrument status
Resolution	Display: 0.1 dB (default), 0.01 dB option selectable in NoiseTools Storage: 0.01 dB
Memory	4 GB as standard (data logging versions) 32 GB factory fitted option
Time history	10 ms, 62.5 ms, 100 ms, 125 ms, 250 ms, 1/2 sec, 1 sec, 2 sec (user selectable)
Audit store	For each measurement, the following data is stored into an independent, non-volatile memory for use with the audit store function:

Specifications	
	<b>Start Time, Duration, LAFMax, LAeq, LCPeak, L10, L90, Overload, Calibration data, Diagnostic information.</b>
VoiceTag audio recording	User selectable recording of voice notes before each measurement for download to NoiseTools software (data logging versions) 30 seconds per recording with audio files downloaded with noise measurement information.
Size	283 x 65 x 30 mm
Weight	300 g /10 oz
Batteries	4 x AA alkaline
Battery life	Typically 12 hours with alkaline batteries Battery life is dependent upon the battery type and quality, and screen brightness
External power	5 V via USB socket from PC 12 V via Multi-IO socket
Tripod mount	1/4" Whitworth socket
Connections	USB Type B to PC Multi-pin IO for external power and communications 3.5mm stereo jack for AC output
Case material	High-impact ABS-PC with soft touch back & keypad
Temperature	Operating: -10 °C to +50 °C Storage: -20 °C to +60 °C
Humidity	Up to 95% RH non-condensing
Electromagnetic performance	IEC 61672-1:2013 Except where modified by EN 61000-6-1:2007 & EN 61000-6-3:2007
Language options	English, French, German, Spanish and Italian
Software support	NoiseTools download, configuration & analysis software as standard. Compatible with Microsoft Windows 7, 8, 8.1, 10 & 11 (32 bit & 64 bit)

## 8.3 Views

### 8.3.1 Sound level view

Sound level:  $L_{xy}$  where  $x = A, C, Z$ ;  $y = F, S, I$

Maximum sound level:  $L_{xyMax}$  where  $x = A, C, Z$ ;  $y = F, S, I$

Minimum sound level:  $L_{xyMin}$  where  $x = A, C, Z$ ;  $y = F, S, I$

Measurement run time

### 8.3.2 Leq view

$L_{xeq}$  where  $x = A, C, Z$

LCPeak, LZPeak, LAPeak

C-A (LCeq-LAeq)

$L_{xE}$  where  $x = A, C, Z$

LAeq,I (also known as LAeq,t) - replaces C-A when impulse time weighting is selected)

Graphical: Short LAeq, LCPeak

Measurement run time

Taktmaximal levels and integrated levels, and 3 and 5 seconds, fast and impulse time-weighted.

### 8.3.3 1:1 octave band view

Graphical display of LF real time octave bands with the highest value for each band (updated every 1/16 seconds)

Graphical display of cumulative Leq for each octave band

Graphical display of cumulative LAeq for each octave band

Numeric display of Leq,1s real time octave bands (updated every 1 second)

Numeric display of cumulative Leq for each octave band

Numeric display of cumulative LAeq for each octave band

Measurement run time

### 8.3.4 1:3 octave band view

Graphical display of LF real time 1:3 octave bands with the highest value for each band (updated every 1/16 second)

Graphical display of cumulative Leq for each band

Graphical display of cumulative LAeq for each band

Numeric display of Leq,1s real time bands (updated every 1 second)

Numeric display of cumulative Leq for each band

Numeric display of cumulative LAeq for each band

Leq,LF and LAeq,LF (20 to 200 Hz)

Instruments with tonal detection capability display tonal bands in blue

### 8.3.5 Ln view

Measures and stores statistical values during measurements.

Provides 14 Ln values to 0.1 dB resolution.

L1.0

L5.0  
 L10.0  
 L50.0  
 L90.0  
 L95.0  
 L99.0

Lns 7-14 are user defined, turned off by default.

Ln values are calculated using 1/16 second LAF samples by default. Sampling rate, time weighting and frequency weighting can be changed in NoiseTools.

Instruments with the “statistical levels x 2” capability provide a second set of 14 Ln values which can be configured within NoiseTools using independent sampling rate, time weighting and frequency weighting.

### 8.3.6 Dose view

Integrator 1	Integrator 2	Integrator 3
Run time	Run time	Run time
Leq1	Leq2	Leq3
LEP,d (Lex)	TWA	TWA
Dose%	Dose%	Dose%
Est dose%	Est dose%	Est dose%
Configuration	Configuration	Configuration

Measurement run time

### 8.3.7 Moving average view

Page 1

LAeq,15min

Indicated in red where LAeq,15min > 95 dB

Indicated in yellow where LAeq,15min > 85 dB

Indicated in white where LAeq,15min ≤ 85 dB

LAeq,15min max

LAeq,15min max date and time

Page 2

LAeq,60min

Indicated in red where LAeq,60min > 100 dB



Indicated in white where  $L_{Aeq,60min} \leq 100$  dB

$L_{Aeq,60min}$  max

$L_{Aeq,60min}$  max date and time

Page 3

LAS

LASMax

LASMax date and time

L95

### 8.3.8 Environmental view

All language selections other than German:

Page 1

$L_{Aeq}$

$L_{Amax}$  \*

L10

L90

Measurement run time

Page 2 (Displayed when the instrument is measuring)

Graphical display of cumulative  $L_{eq}$  for each 1:1 octave band

Page 3 (Displayed when the instrument is measuring)

Graphical display of cumulative  $L_{eq}$  for each 1:3 octave band

Page 4 Graphical display  $L_f$  real time 1:1 octave bands with the highest value for each band (updated every 1/16 second)

Page 5 (Displayed when the instrument is measuring)

Graphical display  $L_f$  real time 1:3 octave bands with the highest value for each band (updated every 1/16 second)

Tonal noise detection when not set to the ISO option (instruments with Tone Detection Capability only).

\* The  $y$  time weighting of the  $L_{Amax}$  can be changed on the View Options / Time Weighting menu.

German Language:

Page 1

$L_{Aeq}$

$L_{Amax}$  \*

L95

C-A ( $L_{Ceq}$ - $L_{Aeq}$ )

$L_{AFT5eq}$

$L_{AFT5eq}$ - $L_{Aeq}$

Measurement run time

Page 2 (Displayed when the instrument is measuring)

- Graphical display of cumulative Leq for each 1:1 octave band
- Page 3 (Displayed when the instrument is measuring)
  - Graphical display of cumulative Leq for each 1:3 octave band
- Page 4 Graphical display Lf real time 1:1 octave bands with the highest value for each band (updated every 1/16 second)
- Page 5 (Displayed when the instrument is measuring)
  - Graphical display Lf real time 1:3 octave bands with the highest value for each band (updated every 1/16 second)
  - Tonal noise detection when not set to the ISO option (instruments with Tone Detection Capability only).

\* The y time weighting of the LA<sub>y</sub>max can be changed on the View Options / Time Weighting menu.

### 8.3.9 Vehicle noise view

Only available when not measuring and requires optional remote push button.

Page 1

- Arithmetic Average LA<sub>rep</sub> value from last three LAS<sub>Max</sub> values
- Current LAS<sub>max</sub> value
- Previous LAS<sub>max</sub> value
- Earliest LAS<sub>max</sub> value

## 8.4 Stored measurements

### 8.4.1 General view

Information about measurement  
Measurement ID

### 8.4.2 Sound level view

- Overall: L<sub>xy</sub>Max where x = A, C, Z; y = F, S, I (9 items)
- Overall: L<sub>xy</sub>Min where x = A, C; Z; y = F, S, I (9 items)
- Time history: L<sub>xy</sub>Max where x = A, C; y = F, S, I (6 items)
- Measurement run time
- Time & date of measurement start
- Time history data rate is user configurable in the global settings

### 8.4.3 Leq View

- Overall: LC<sub>Peak</sub>, LZ<sub>Peak</sub>, LA<sub>Peak</sub>, LA<sub>eq</sub>, LC<sub>eq</sub>, LZ<sub>eq</sub> (6 items).
- Time history: LA<sub>eq</sub>, LC<sub>eq</sub>, LZ<sub>eq</sub>

Time history: LCPeak, LZPeak, LAPeak

Time history: LAeqL (also known as LAeq,t)

Time history data rate is user configurable in the global settings

Measurement run time

Time & date of measurement start

#### 8.4.4 Dose view

Overall: Leq2, Leq3. (Lavg stored, TWA, % dose & est % dose also available)

Time history: Leq2, Leq3

Time history data rate is user configurable in the global settings

Measurement run time

Time & date of measurement start

Integrator 1 values are stored in the Leq module

#### 8.4.5 1:1 octave band view

Overall Leq for each octave band

Overall LAeq for each octave band

NR & NC values (CR:16xD version, CR:17xA,B & C versions)

Time history: Leq for each octave band (10 items) stored at the global data rate (minimum duration of 1/16 seconds)

Measurement run time

Time & date of measurement start

#### 8.4.6 1:3 octave band view

Overall Leq for each octave band 36 items from 6.3 Hz to 20 kHz

Overall LAeq for each octave band 36 items from 6.3 Hz to 20 kHz

Leq,LF and LAeq,LF (20 to 200 Hz)

Time history: Leq for each 1:3 octave band. 36 items from 6.3 Hz to 20 kHz stored at the global data rate (minimum duration of 1/16 seconds)

Measurement run time

Time & date of measurement start

#### 8.4.7 Ln view

14 Ln values for each measurement in Ln set #1

14 Ln values for each measurement in Ln set #2 (CR:171C & CR:172C)

#### 8.4.8 Moving average view

On instruments with firmware version 2.8 or above:

---

## Page 1

LAeq,15min Max  
LAeq,15min Max date and time

## Page 2

LAeq,60min Max  
LAeq,60min Max date and time

## Page 3

LASMax  
LASMax date and time  
L95

On instruments with firmware version below 2.8:

## Page 1

LASMax  
LA95

## Page 2

LASMax  
LA95

#### 8.4.9 Menu/quick settings

The quick settings available are:

UK: 3 dB, no threshold, no time weighting, criterion level of 85 dB

EU: 3 dB, no threshold, no time weighting, criterion level of 85 dB

#### OSHA HC & PEL

Integrator 2: 5 dB, 80 dB threshold, slow time weighting, 90 dB criterion level

Integrator 3: 5 dB, 90 dB threshold, slow time weighting, 90 dB criterion level

#### OSHA HC & ACGIH

Integrator 2: 5 dB, 80 dB threshold, slow time weighting, 90 dB criterion level

Integrator 3: 3 dB, no threshold, slow time weighting, 85 dB criterion level

#### MSHA HC & EC

Integrator 2: 5 dB, 80 dB threshold, slow time weighting, 90 dB criterion level

Integrator 3: 5 dB, 90 dB threshold, slow time weighting, 90 dB criterion level

#### Custom

Custom settings defined by the NoiseTools software.

## 8.5 Electrical outputs

### 8.5.1 AC output

The AC output is provided on the 3.5 mm jack socket at the bottom of the instrument.

Do not use a stereo jack plug in this socket. Only use a 3.5 mm mono jack plug.

The AC output has four settings: a combination of high or low levels and a 0 dB or +20 dB gain.

Voltages and full-scale levels are as follows:

High levels (70-140 dB)

0 dB gain	1.3 V <sub>pk-pk</sub>	(450 mV <sub>rms</sub> ) at full scale 140 dB
+20 dB gain	1.7 V <sub>pk-pk</sub>	(600 mV <sub>rms</sub> ) at full scale 132 dB

Low levels (20-90 dB)

0 dB gain	400 mV <sub>pk-pk</sub>	(140 mV <sub>rms</sub> ) at full scale 90 dB
+20 dB gain	1.3 V <sub>pk-pk</sub>	(450 mV <sub>rms</sub> ) at full scale 90 dB

The output is unweighted, i.e. Z-weighted.

AC output cables

The AC output should be used with a ZL:174, ZL:177 or ZL:185 cable.

These cables are available from Cirrus Research plc or your local distributor. Do not use any other cable with the instrument. This may damage the instrument and invalidate your warranty.

### 8.5.2 DC output

The DC output is provided on the 18-pin Multi-IO socket at the bottom of the instrument. The output is set to 25 mV/db with LAF updated 16 times per second.

DC output cables

The DC output is available using a ZL:174 output cable.

This cable is available from Cirrus Research plc or your local distributor. Do not use any other cable with the Optimus. This may damage the instrument and invalidate your warranty.

---

### 8.5.3 Threshold triggered output

An external discrete available on the 18 Pin Multi-IO socket at the bottom of the instrument can be triggered when an audio trigger event is detected. This trigger will toggle the output from 0 to 3.3V and can be used to trigger external devices, for example a camera or noise warning sign.

The trigger output can be enabled in NoiseTools as an event when an audio trigger occurs.

The trigger output is available on the 18 pin Multi-IO Cable ZL:183 wires (black-return, brown – trigger).

The trigger output is a TTL output. To avoid damage to the instrument do not apply any external voltage to this signal and limit current drawn to less than 2mA.

### 8.5.4 Cables

Optimus sound level meters can be used with a range of cables. The standard cables are listed below.

#### Microphone extension cables

ZL:205 - 5 m microphone extension cable

ZL:210 - 10 m microphone extension cable

ZL:225 - 25 m microphone extension cable

#### Input and output cables

ZL:100 - 1m USB cable

ZL:171 - Optimus power input cable, 2.1 mm Power Jack, 2m

ZL:172 - Optimus printer cable, 18-way to 6-way RJ12, 1m

ZL:173 - Optimus DPU-414 printer cable, 18-way to 9-way D male, 1m

ZL:174 - Optimus AC & DC output, 18-way to 2 x phono, 1m

ZL:175 - Optimus PC cable, 18-way to RS232 9-pin D female, 1m

ZL:176 - Optimus 12 V battery pack cable 2 m to tinned ends with inline fuse

ZL:177 - Optimus AC output cable, 3.5 mm mono to 3.5 mm stereo jack, 2m

ZL:179 - Optimus cable for ZE:910 isolator, 18-way to tinned ends, 1m

ZL:180 - Optimus modem cable, 18-way to RS232 9-pin D male with 12 V power input 2.1 mm jack, 1m

ZL:181 - Optimus PC cable, 18-way to RS232 9-pin D female with 12V power input 2.1 mm jack, 1m

ZL:182 - Optimus Fujitsu printer cable, 18-way to multiway, 1m

ZL:183 - Optimus all-purpose cable, 18-way to tinned ends, 2m

ZL:184 - Optimus Hirose HR30 male to male SR30, 1m

ZL:185 - Optimus AC output cable, 18-way to phono, 1m

ZL:186 - Optimus USB cable with Ferrite, USB A to USB B, 1.8m

ZL:150 - Optimus vehicle noise push button

## 9 Acoustic calibrator information

This chapter refers to the use of a Cirrus Research plc CR:517, CR:514 or CR:515 acoustic calibrator.

### 9.1 Setting up the calibrator

Press the power button on the end of the calibrator to switch the unit on. The indicator will illuminate to show that the unit is operating. The calibrator will automatically switch off after five minutes to preserve battery power.

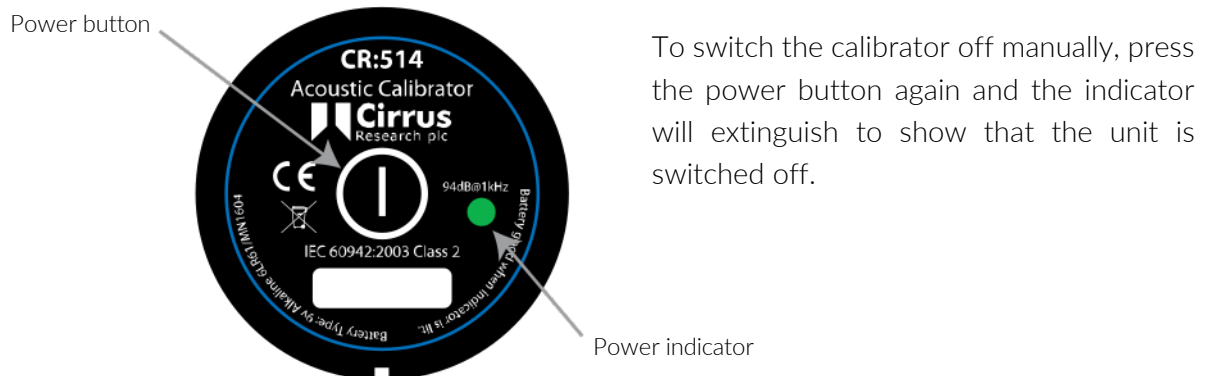

#### *Permanent-on mode*

For some applications there may be a need to have the calibrator switched on continuously. To allow for this, the calibrator can be turned on by pressing and holding the power button for three seconds. Release the button and the indicator will flash to show that the unit is in permanent-on mode. Press the power button again to switch off the calibrator.

### 9.2 Calibrating a sound level meter

Push the microphone of the sound level meter into the cavity at the end of the calibrator. Ensure the microphone is fully inserted into the cavity and is past the 'O' ring seals.

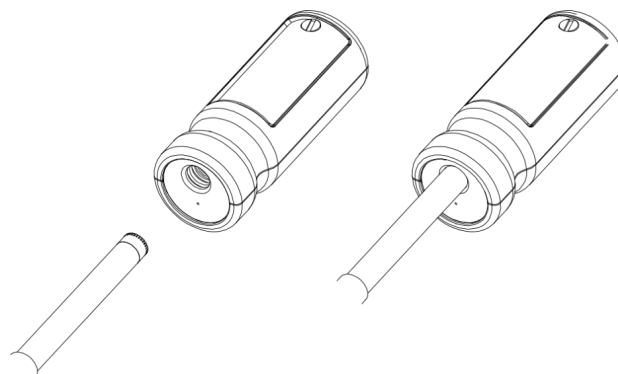

The microphone should be parallel to the body of the calibrator. Also ensure that the small bleed-hole next to the microphone cavity is not blocked as this could cause damage to the microphone.

Your Optimus sound level meter will automatically make adjustments for the level produced by the acoustic calibrator and the microphone type fitted to the instrument.

### 9.2.1 Background noise

In order for the calibrator to operate as intended, the ambient acoustic noise level should be no greater than 80 dB(A).

### 9.2.2 Stabilisation

In order for the sound pressure level and frequency to stabilise after switching the calibrator on when coupled to a microphone, a period of at least three seconds should be allowed before performing a calibration.

## 9.3 Changing the battery

The CR:517, CR:514 and CR:515 acoustic calibrators use a single 9 V alkaline battery. This type of battery is known as 6F22 or NEDA 1604. It is also commonly known as PP3.

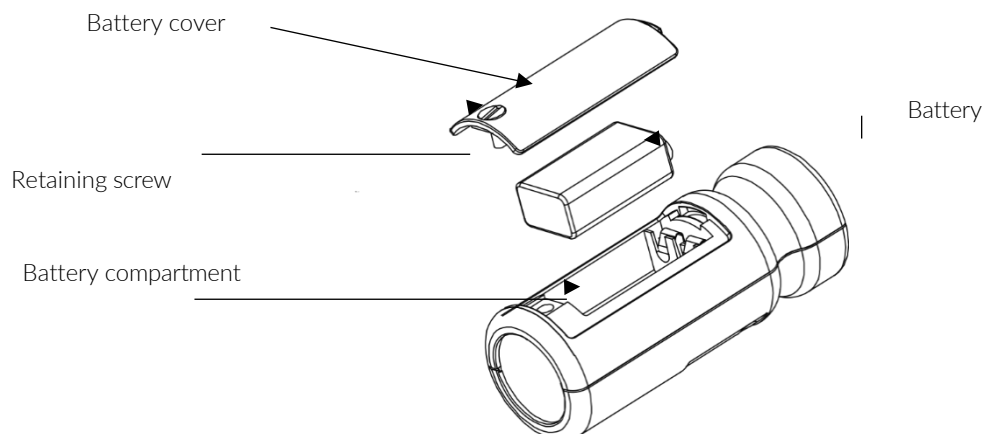

1. Unscrew the screw holding the battery cover on, using a coin or the keyring provided.
2. The battery can now be eased out of its holder and replaced. The battery should be eased out terminal side first by pushing against the spring at the other end.

Ensure that the battery is inserted with the correct polarity, with the negative terminal in contact with the larger cut out.



### 9.3.1 Battery type

The battery should be an alkaline battery, not an ordinary dry cell. The battery is 9 volts when new and will operate the calibrator down to 6.4 volts.

When the battery voltage is below 6.6 volts but above 6.4 volts, the power LED will flash to indicate that the battery voltage is low. When the battery voltage is below 6.4 volts, the calibrator will not switch on.

A discharged battery may allow switch-on but will soon drop in voltage and indicate low battery or switch off.

## 9.4 Specifications

Frequency	1 kHz $\pm$ 1%
Sound level	94 dB re 20 $\mu$ Pa
Standardisation	CR:514 - IEC 60942:2017 Class 2 CR:515 - IEC 60942:2017 Class 1 CR:517 - IEC 60942:2017 Class 1
Distortion	Less than 2%
Operating humidity	25 to 90% relative humidity
Operating static pressure	65 kPa to 108 kPa
Operating temperature	-10°C to +50°C
Storing temperature	-20°C to +60°C
Effective volume	6.19 $\pm$ 0.2 cm <sup>3</sup>
Cavity diameter	0.525 inch
Battery	1 x 9 V 6F22 (NEDA 1604)
Battery life	Approx. 15 Hours Continuous Use
Battery voltage	9 V Nominal (10 V max, 6.4 V min)
Weight with battery	185 g
Dimensions	120 mm x $\varnothing$ 48 mm

## 9.5 Technical information

### 9.5.1 Free Field Correction

When calibrating a microphone that is to be used for free field measurements, a small correction may be necessary to compensate for the difference between the microphone's free field response at 'zero degrees' or 'head-on' incidence, and the pressure level generated by the calibrator.

The correction is typically -0.3 dB for Cirrus ½ inch microphones (making the effective calibration level 93.7dB).

---

An example of the procedure used to calculate the value for an MK:224, MK:229 or MK:216 microphone is shown below:

Level = 94.0 dB + microphone correction

Level = 94.0 dB + ( -0.3 dB)

Level = 93.7 dB

---

## 10 Declaration of Conformity

Manufacturer: Cirrus Research plc  
Acoustic House  
Bridlington Road  
North Yorkshire  
YO14 0PH  
United Kingdom



Equipment description.

The following equipment manufactured after 1st January 2018:

CR:151 Sound Level Meter (A & B Versions)  
CR:152 Sound Level Meter (A & B Versions)  
CR:161 Sound Level Meter (A, B, C & D Versions)  
CR:162 Sound Level Meter (A, B, C & D Versions)  
CR:171 Sound Level Meter (O, A, B & C Versions)  
CR:172 Sound Level Meter (O, A, B & C Versions)  
CR:19x Sound Level Meter (All versions)  
CR:514, CR:515 and CR:517 Acoustic Calibrator  
Along with standard accessories

According to:

EMC Directive 2014/30/EU  
Low Voltage Directive 2014/35/EU  
RoHS Directive 2011/65/EU

Meet the following standards:

EN 61000-6-3:2007+A1:2011

Electromagnetic compatibility (EMC). Generic standards. Emission standard for residential, commercial and light-industrial environments

EN 61000-6-1:2007

Electromagnetic compatibility (EMC). Generic standards. Immunity for residential, commercial and light-industrial environments

Auxiliary Industry Standards

EN 61672-1:2013	Electroacoustics – sound level meters
EN 61260:1995	Octave-band filters
EN 60942:2017	Sound calibrators

Signed

Dated 24th April 2023

A handwritten signature in black ink, appearing to be 'Mark Swale'.

Mark Swale, Chief Engineer



## 11 Product guarantee and extended warranty

1. Every new product is provided with a 12-month no-quibble warranty. This covers everything we provide against failure, poor workmanship and accidental damage.

*NB - European Union law states a product has to be fit for purpose for 24 months after purchase. This two-year period covers failure and poor workmanship only.*

2. If the product is calibrated by Cirrus Research or an authorised calibration and service centre, then the initial 12-month warranty is extended by a further 12 months, with the same conditions, for up to 15 years in total.
  3. If a product has not been calibrated annually by Cirrus Research or an authorised calibration and service centre, then you may buy back into the warranty scheme for a small fee, plus the cost of calibration. This can only be done once during the life of the product.
  4. If a microphone capsule fails under warranty and is physically damaged, we will replace it with a refurbished capsule.
  5. If you don't wish to have a refurbished capsule, then you can trade in your damaged capsule for a new one, which will incur a fee.
-

The following pages are left blank intentionally







[www.cirrusresearch.co.uk](http://www.cirrusresearch.co.uk)  
[sales@cirrusresearch.com](mailto:sales@cirrusresearch.com)